

Ordering Guide:

EX	xxxW	STAx	Y	Z	D	A
Explosion Proof	Wattage	Product Series	Sensor Options	Color	Beam Angle	Glass Type

Dimension(mm):

EX-xxxW-STA1

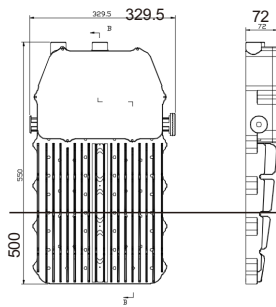

EX-xxxW-STA2

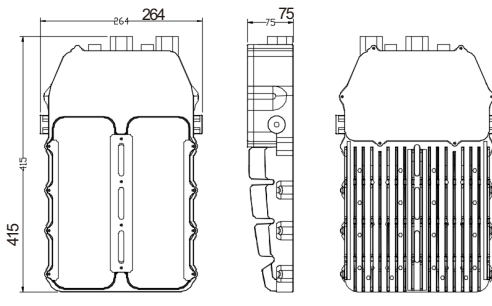

EX-xxxW-STA3

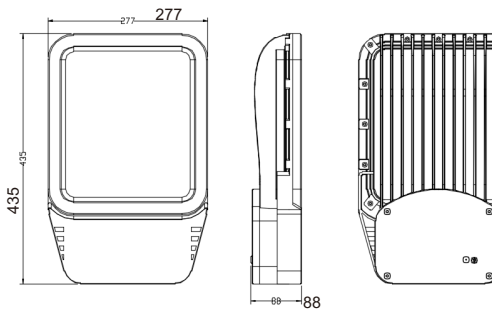

Description:

STA Series is an explosion proof street light, mainly used as factory or road lighting. It's suitable for explosive hazardous environments such as petroleum extraction, storage, chemical industry, medicine, military industry and military facilities. It is waterproof and dust-proof, without internal cleaning and maintenance. The lamp is made of explosion-proof joint surface, beautiful appearance, simple structure and easy installation, it will never corrode and rust in damp, high temperature and other harsh environments.

Technical Specification:

Model NO.	EX-xxx W-STA1	EX-xxx W-STA2	EX-xxx W-STA3
Wattage	100~250W	10~150W	
UL844 Standard	Class I, Division 2 Groups A, B, C, D Class II, Division 1 Groups E, F, G Class II, Division 2 Groups F, G Class III UL1598 UL1598A		
Housing Material	ADC12 Aluminum + Tempered Glass		
Input Voltage	AC100-305V/ AC180-528V/ AC90-305V/ AC277-480V		
Lumen Efficiency	120-140 lm/W		
CCT	2700-7000K		
CRI	> 70		
Beam Angle	Type III '40° /60° /90° /120°		
Operation Temperature	-40℃/-40°F ~ 60℃/140°F (10W-100W) ; -40℃/-40°F ~ 60℃/140°F (100W-250W)		
IP Rating	IP66/IP67		
IK	09		
Dimming	0-10V		
Packing Size	692*388*125 mm 27.24*15.28*4.92 inch	560*320*127mm 22.05*12.6*5 inch	744*332*216mm 29.29*13.07*8.5 inch
Net Weight	9.5 kg/ 20.94 lbs	6.5 kg/ 14.33 lbs	7.3 kg/ 16.09 lbs
Gross Weight	10.5 kg/ 23.15 lbs	7.5 kg/ 16.53 lbs	8.3 kg/ 18.3 lbs

EX-xxxW-STA1		EX-xxxW-STA2		EX-xxxW-STA3	
AC100-305V	AC90-305V	AC100-305V	AC90-305V	AC100-305V	AC90-305V
AC100-305V	AC90-305V	AC100-305V	AC90-305V	AC100-305V	AC90-305V
AC100-305V	AC90-305V	AC100-305V	AC90-305V	AC100-305V	AC90-305V
AC100-305V	AC90-305V	AC100-305V	AC90-305V	AC100-305V	AC90-305V
AC100-305V	AC90-305V	AC100-305V	AC277-480V	AC100-306V	AC90-305V
AC100-305V	AC90-305V	AC100-305V	AC277-480V	AC100-307V	AC277-480V
AC100-305V	AC90-305V	AC180-528V		AC100-308V	AC277-480V
AC100-305V	AC277-480V				
AC180-528V	AC277-480V				
AC180-528V	AC277-480V				
AC180-528V					
AC180-528V					

Accessories & Mounting Kit:

EX-xxxW-STA1/2

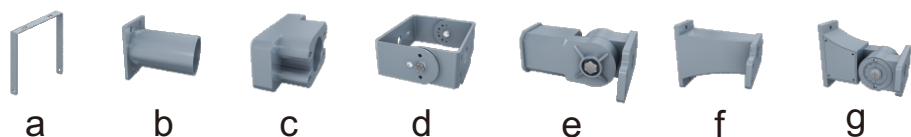

- a. Hardware mounting bracket
- b. Light pole mounting bracket
- c. Adapter bracket

- d. Trunnion mounting kit(TM)
- e. Slip fitter mounting kit(SF)
- f. Arm mounting kit A (AM-A)

- g. Adjustable arm mounting kit B(AM-B)

EX-xxxW-STA3

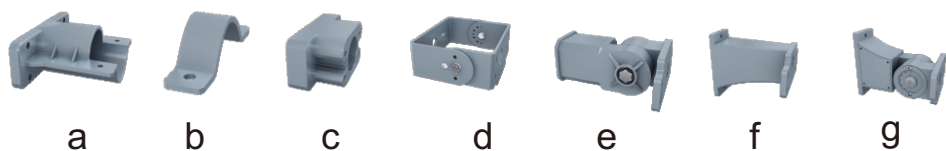

- a. Light pole Mounting bracket
- b. Hoop
- c. Adapter bracket

- d. Trunnion mounting kit(TM)
- e. Slip fitter mounting kit(SF)
- f. Arm mounting kit A (AM-A)

- g. Adjustable arm mounting kit B(AM-B)

Photometric Data:

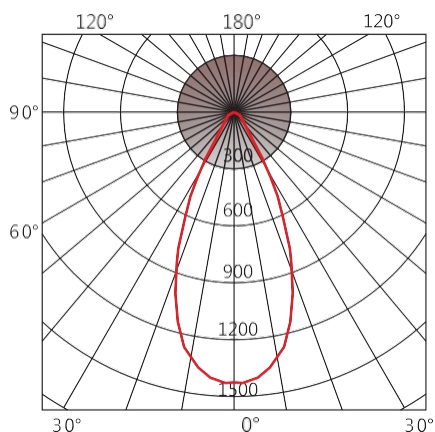

Ratio of distance to height: 0.7

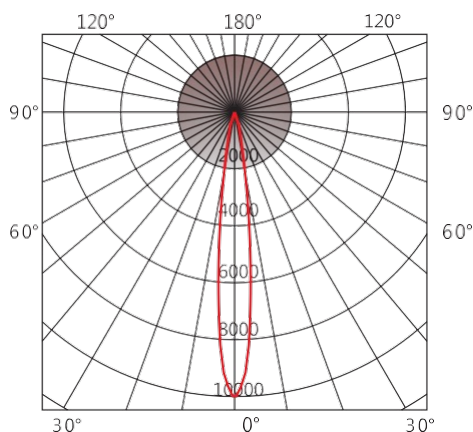

Ratio of distance to height: 0.23

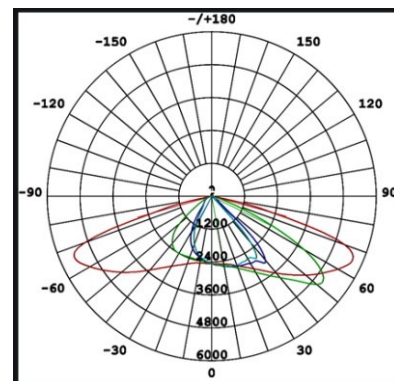

Type III