

# LED STRIP LIGHT



## Description:

This strip light is mainly for commercial use. It can be used in warehouse, office, garage, display shops and other commercial applications.

## Features:

- Five year limited warranty against defects in manufacturing.
- Minimize labor and recycling costs.
- Minimize replacements and maintenance costs.
- Anti-glare design and suitable for damp locations.
- App or panel switch wireless control.
- Motion detection integrated sensor.
- Emergency Batter option available.



## Specifications:

Model	Wattage(W)	Voltage	Lumens/W	Warranty	CRI	Size
ST36W4FTDCCT3-5FJ01-BT/MO	36W	100-277VAC	130	5 Years	>80	48"x3.35"x3.56"
ST50W4FTDCCT3-5FJ01-BT/MO	50W					

# LED STRIP LIGHT

## Dimming Connection

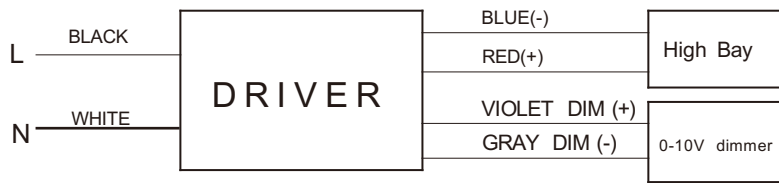

## Ordering Guide

**ST -xxW 4FT D CCT3-5 F J01BT/MO**

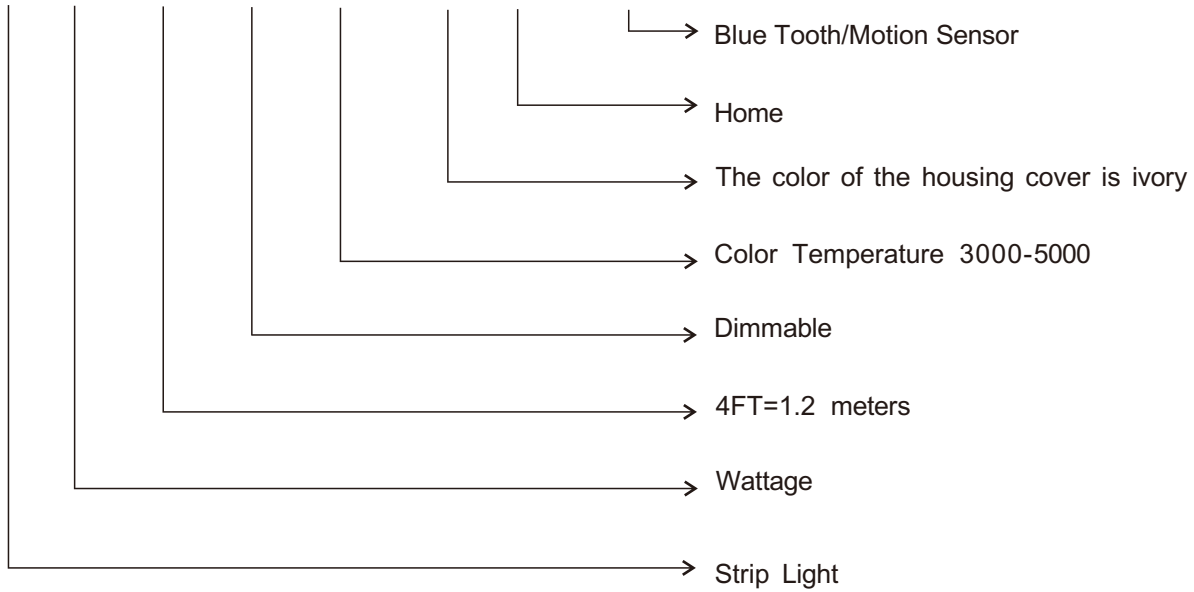

## Packing Information

Product	ST36W4FTDCCT3-5F J01-BT/MO	ST50W4FTDCCT3-5F J01-BT/MO
PC/Carton	6	
Packing Size(mm)	1305×335×240	
Packing Weight(KG)	19.5	

## Installation:

Tools Requirements:

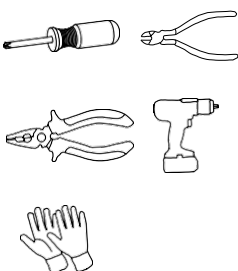

Packing list:

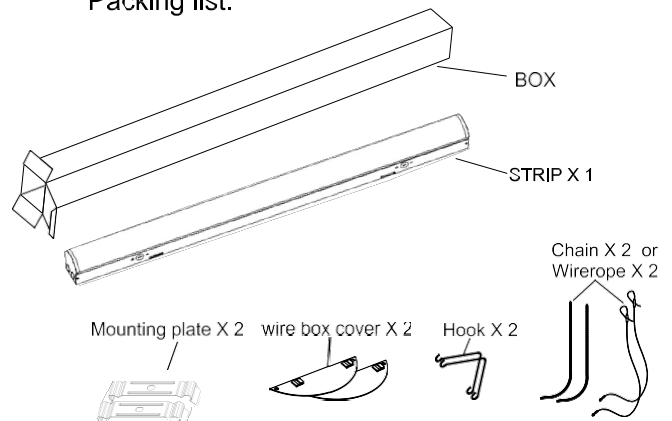

ALINA LIGHTING SOLUTIONS

# LED STRIP LIGHT

Mounting options:

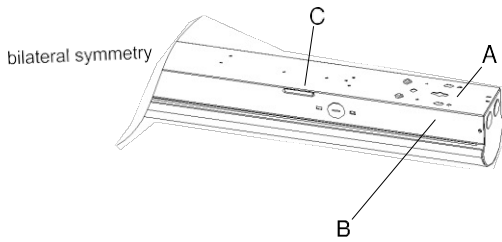

- A. Chain and V hook mounting.
- B. Surface mounting.
- C. mounting plate installation.

Installation Steps:

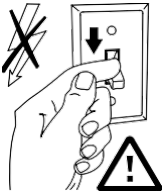

**WARNING:**  
Before installation,  
turn power off.

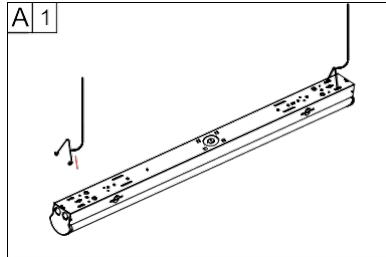

1. Tie hook with chain (or wire rope) and then insert it into installation hole.

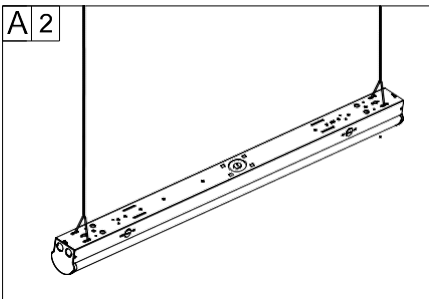

2. Fix chain to installation location, adjust the height of chain until fixture is balanced.

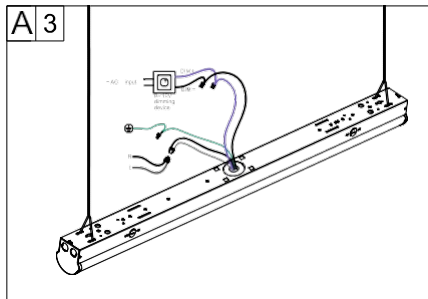

3. Connect AC wire and dimming wire.

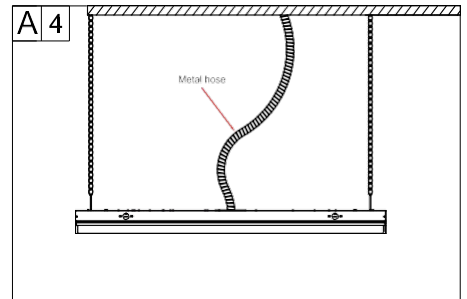

4. Wrap wires with metal material.

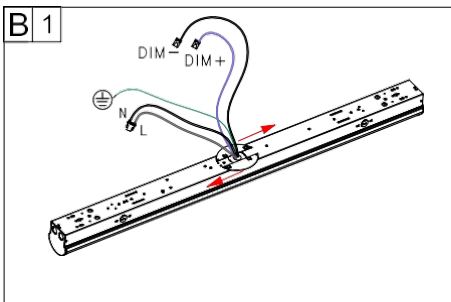

1. Lock the wire box cover.

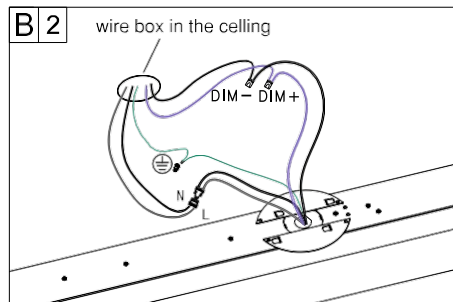

2. Connect AC wire and dimming wire.

## Notice:

If there is no wire box in the ceiling, you can not use the wire box cover.

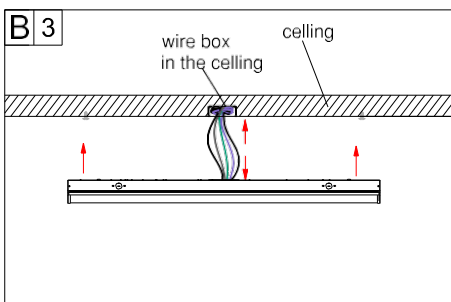

3. Lift up the fixture and put wires into box.

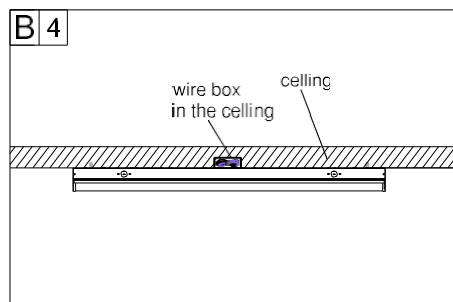

4. Lock the fixture by nail.

## Notice:

If you don't use dimming wire, please insulate both ends of dimming wire.



# LED STRIP LIGHT

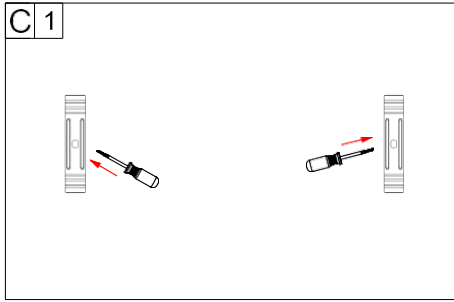

1. Lock the mounting clasp with a screwdriver

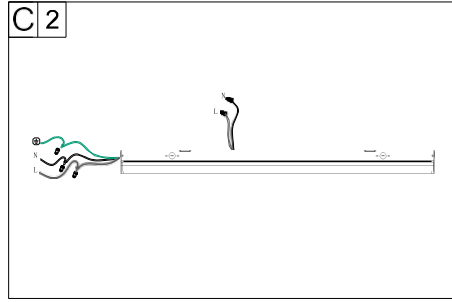

2. Connect wire. If connect wire at side, please insulate both ends of AC wire at the bottom.

## WARNING:

If connect wire at side, please insulate both ends of AC wire at the bottom.

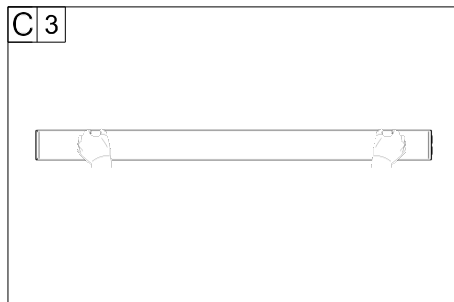

3. Press the luminaire by hand to make the luminaire buckle firmly

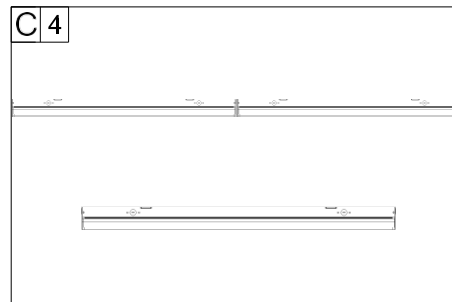

4. Put the wire back in the box. Multiple fixtures can be installed on a line. But can not be connected to more than 10 fixtures, because of wire load limited.

## Notice:

Multiple fixtures can be installed on a line. But can't be connected to more than 10 fixtures, because of wire load limited.

## Three choices to control:

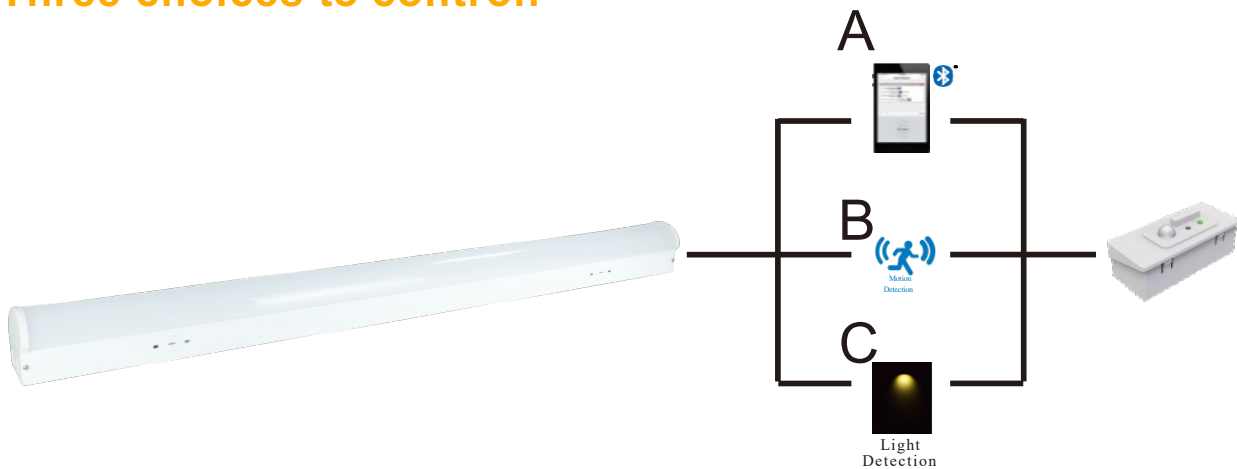

## Details of the product:

